

CONTRACT: DL00139 PROJECT 12B.101811

STATE OF NORTH CAROLINA
DIVISION OF HIGHWAYS

CATAWBA COUNTY

LOCATION: BRIDGE #91, CATAWBA CO., NC127 OVER LAKE HICKORY

STATE	STATE PROJECT REFERENCE NO.	SHEET NO.	TOTAL SHEETS
N.C.	12B.101811	1	
STATE PROJ. NO.	F.A. PROJ. NO.	DESCRIPTION	
12B.101811	N/A	P.E.	
12B.101811	N/A	CONST	

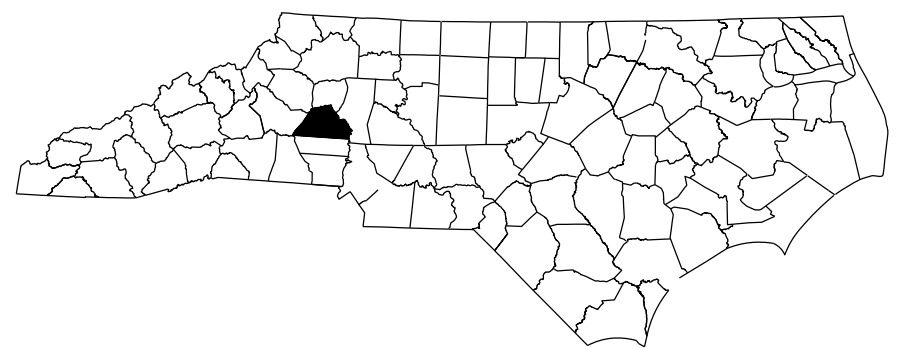

BRIDGE #91

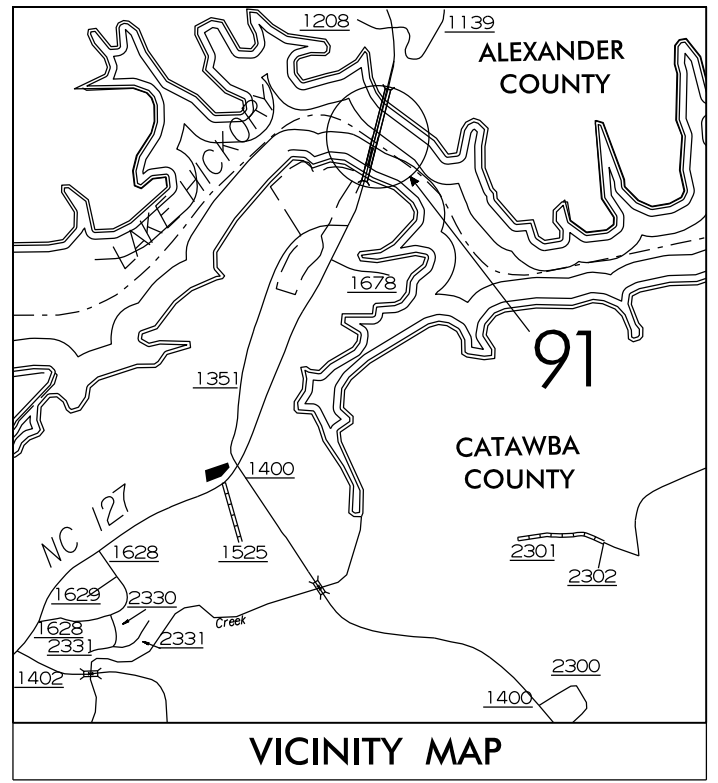

TYPE OF WORK: INSTALLATION OF SOIL NAILS AND GROUND ANCHORS

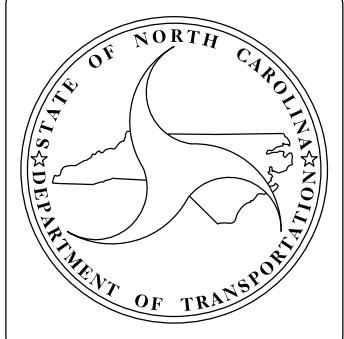

DESIGN DATA
CATAWBA
#91 ADT 2011 = 20000

PROJECT LENGTH
BRIDGE #91 = 0.02 MILE

Prepared in the Office of:
DEPARTMENT OF TRANSPORTATION
DIVISION OF HIGHWAYS
STRUCTURES MANAGEMENT UNIT - PRESERVATION & REPAIR GROUP
1000 BIRCH RIDGE DR. RALEIGH, N.C. 27610

RICK NELSON, P.E.
PROJECT ENGINEER

DocuSigned by:
ENGINEER
Timothy M. Shearill
AD50B1D972704C40A
PROFESSIONAL
SEAL
18565
ENGINEER
TIMOTHY M. SHEARILL

4/19/2017
PROJECT DESIGN ENGINEER

LETTING DATE: MAY 9, 2017

CONTRACT: DL00139 PROJECT 12B.101811

STATE OF NORTH CAROLINA
DIVISION OF HIGHWAYS

CATAWBA COUNTY

STATE	STATE PROJECT REFERENCE NO.	SHEET NO.	TOTAL SHEETS
N.C.	12B.101811	1A	
STATE PROJ. NO.	F.A. PROJ. NO.	DESCRIPTION	
12B.101811	N/A	P.E.	
12B101811	N/A	CONST	

INDEX OF SHEETS

<i>SHEET NUMBER</i>	<i>DESCRIPTION</i>
<i>1</i>	<i>TITLE SHEETS</i>
<i>1A</i>	<i>INDEX OF SHEETS</i>
<i>S-1 THRU S-4</i>	<i>STRUCTURAL PLANS</i>
<i>SN</i>	<i>STANDARD NOTES</i>

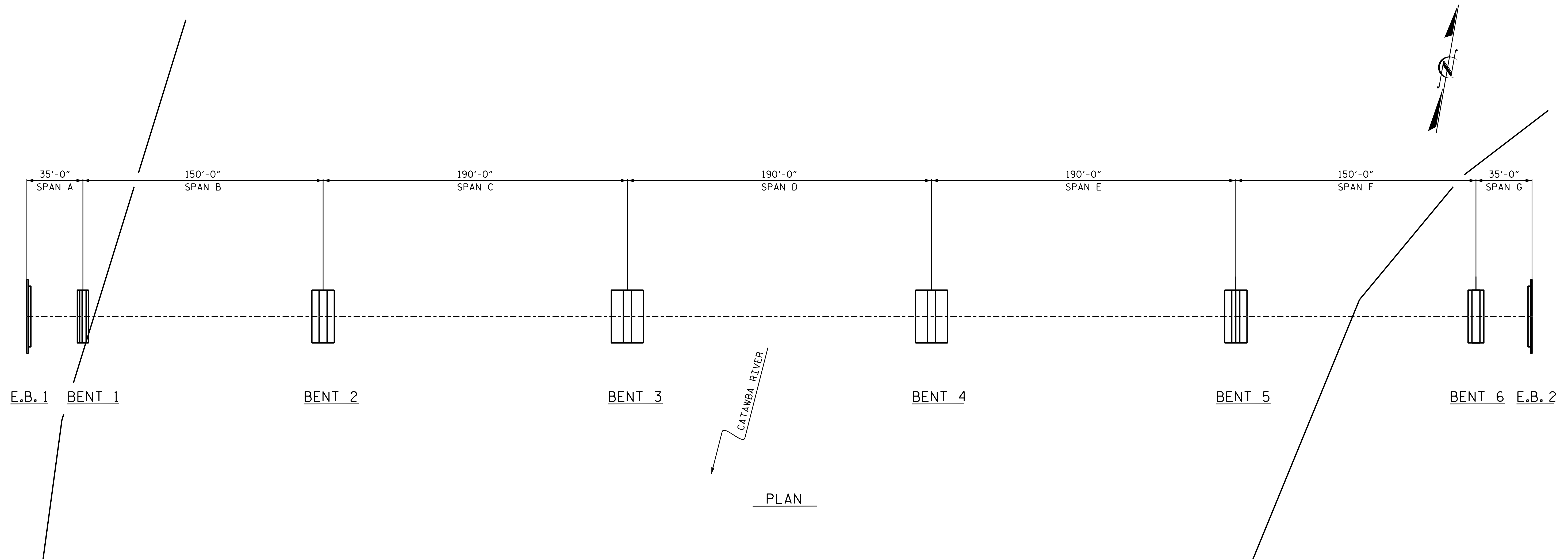

PLAN

TYPE OF WORK: INSTALLATION OF SOIL NAILS THROUGH NEW INTEGRAL CURTAIN WALL AND GROUND ANCHORS THROUGH BENT CAPS

NOTES

EXISTING DIMENSIONS AND BRIDGE CONDITIONS ARE FROM BEST INFORMATION AVAILABLE. THE CONTRACTOR SHALL FIELD VERIFY THE INFORMATION INDICATED ON THE PLANS AND NOTIFY THE ENGINEER IF ACTUAL DIMENSIONS AND CONDITIONS DIFFER.
IT IS THE CONTRACTOR'S RESPONSIBILITY TO FOLLOW ALL STATE AND FEDERAL SAFETY REQUIREMENTS.

FOR "FALSEWORK AND FORMWORK," SEE SPECIAL PROVISIONS.
FOR "SUBMITTAL OF WORKING DRAWINGS," SEE SPECIAL PROVISIONS.
FOR "SOIL NAIL PROOF TESTS," SEE SPECIAL PROVISIONS.
FOR "SOIL NAILS," SEE SPECIAL PROVISIONS.

FOR "GROUND ANCHORS", SEE SPECIAL PROVISIONS.
FOR "GROUND ANCHOR PROOF TESTS", SEE SPECIAL PROVISIONS.
FOR "CRANE SAFETY," SEE SPECIAL PROVISIONS.
FOR "WORK IN, OVER, OR ADJACENT TO NAVIGABLE WATERS", SEE SPECIAL PROVISIONS.

PROJECT NO. 12B.101811
CATAWBA COUNTY
BRIDGE NO. 91

STRUCTURE TOTAL BILL OF MATERIAL

SOIL NAIL PROOF TESTS	GROUND ANCHOR PROOF TESTS	SOIL NAILS	GROUND ANCHORS
EA	EA	EA	EA
2	10	12	10

STATE OF NORTH CAROLINA
DEPARTMENT OF TRANSPORTATION
RALEIGH

GENERAL PLAN AND BILL OF MATERIAL

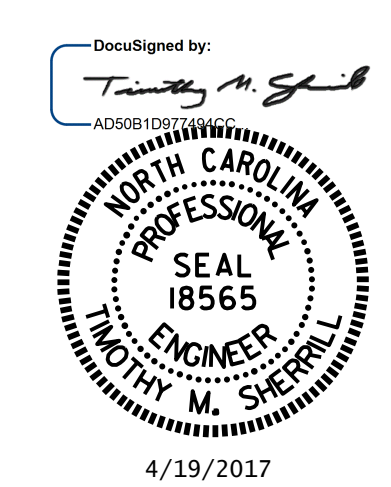

DRAWN BY : R. WEISZ DATE : 9/12
CHECKED BY : T. SHERRILL DATE : 06/13

REVISIONS						SHEET NO.
NO.	BY:	DATE:	NO.	BY:	DATE:	S-1
1			3			TOTAL SHEETS
2			4			4

GENERAL NOTES:

EXISTING BRIDGE DETAILS INDICATED ON THE PLANS ARE FROM THE BEST INFORMATION AVAILABLE. SINCE THIS INFORMATION IS SHOWN FOR THE CONVENIENCE OF THE CONTRACTOR, THE CONTRACTOR SHALL HAVE NO CLAIM WHATSOEVER AGAINST THE DEPARTMENT OF TRANSPORTATION FOR ANY DELAYS OR ADDITIONAL COST INCURRED BASED ON DIFFERENCES BETWEEN THE EXISTING BRIDGE AND REPAIR DETAILS SHOWN ON THE PLANS AND THE ACTUAL CONDITIONS AT THE PROJECT SITE.

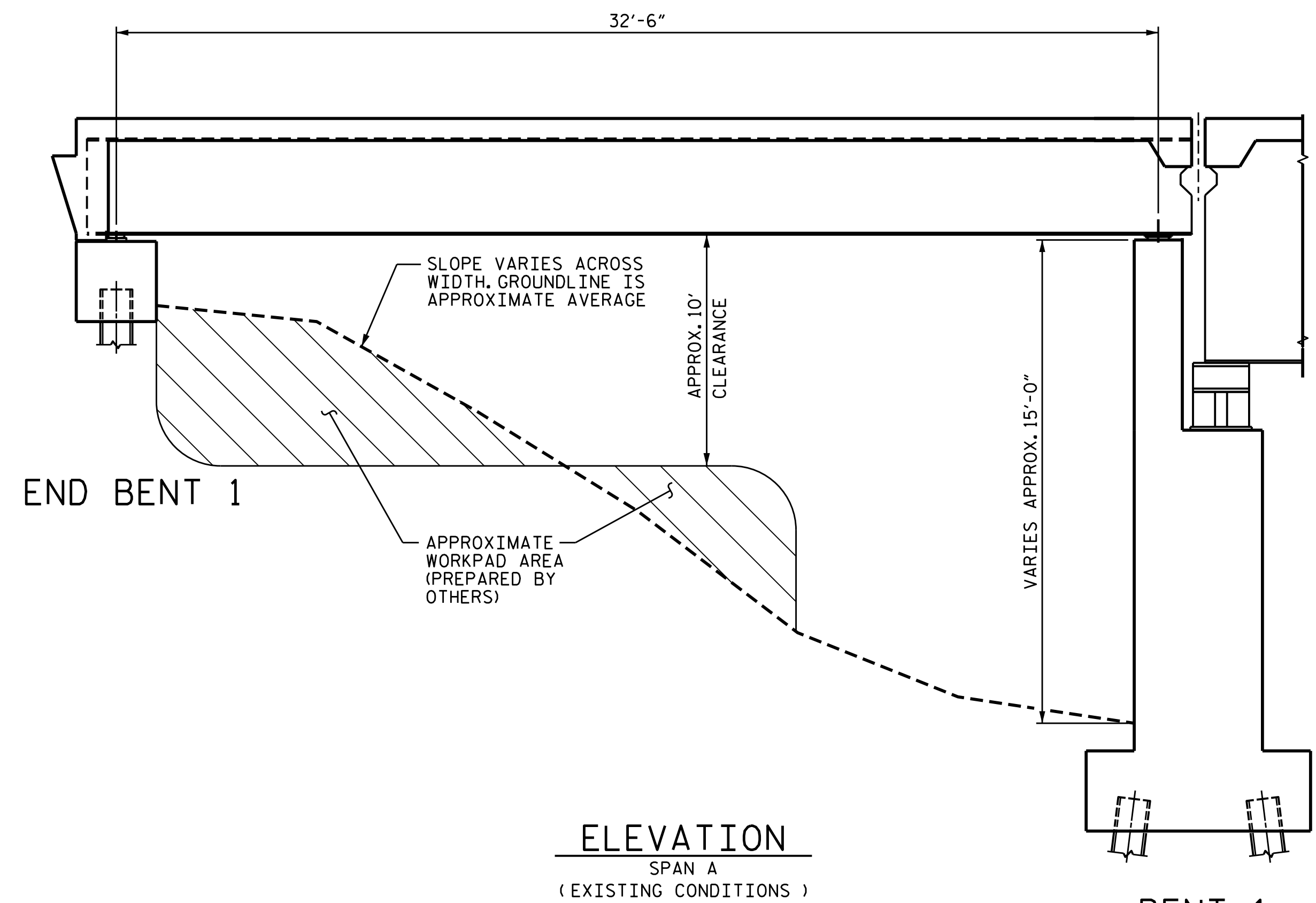
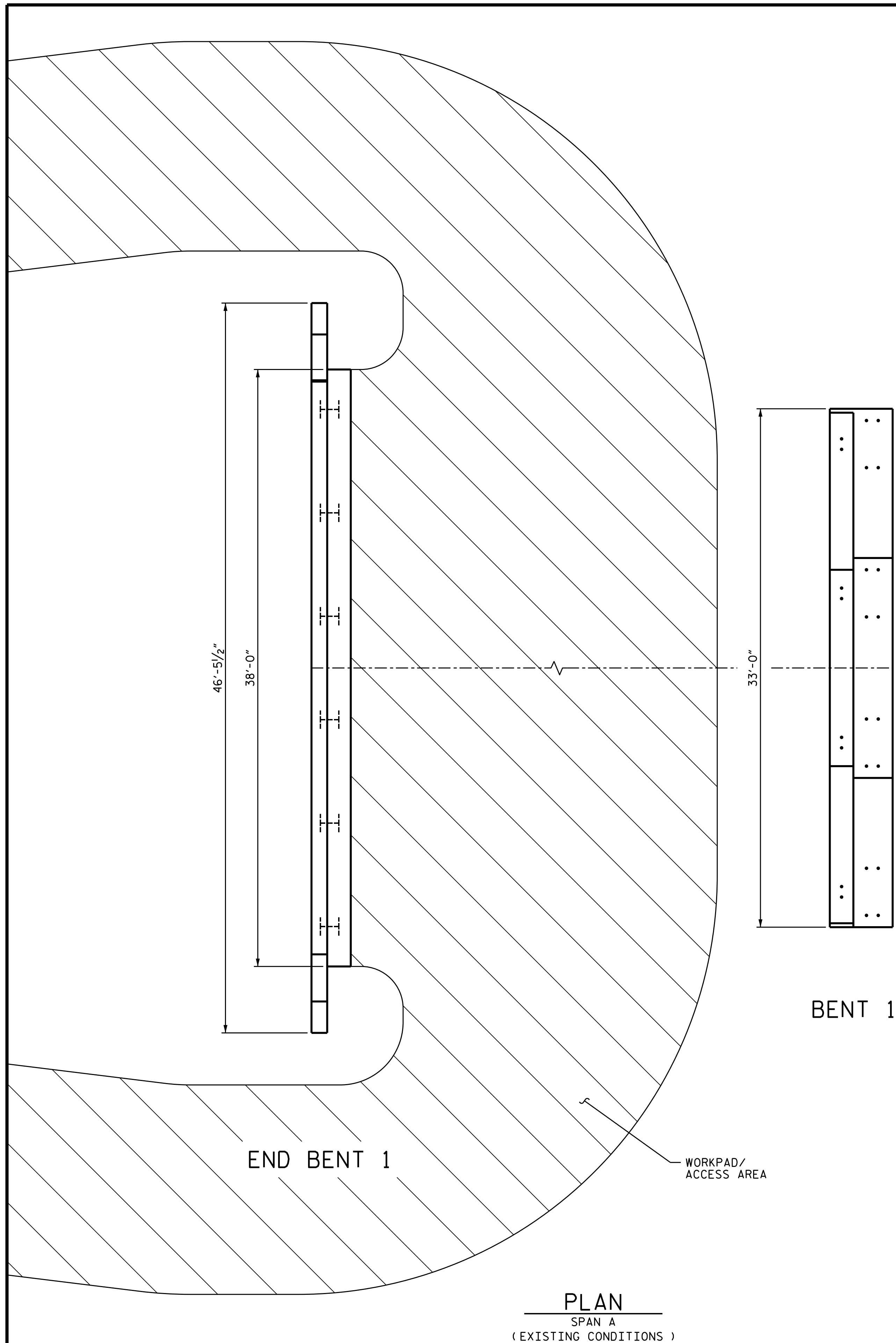

END BENT 1 INDICATED,
END BENT 2 SIMILAR

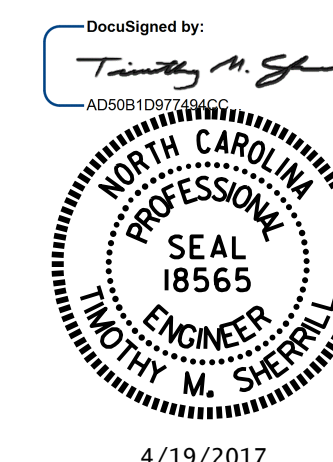

PROJECT NO. 12B.101811
CATAWBA COUNTY
 BRIDGE NO. 91

STATE OF NORTH CAROLINA
 DEPARTMENT OF TRANSPORTATION
 RALEIGH

**END BENT AND
 APPROACH SPAN
 TYPICAL LAYOUT
 AND GEOMETRY**

DRAWN BY : R. WEISZ DATE : 1/13
 CHECKED BY : T. SHERRILL DATE : 3/13

REVISIONS						SHEET NO.
NO.	BY:	DATE:	NO.	BY:	DATE:	S-2
1			3			TOTAL SHEETS
2			4			4

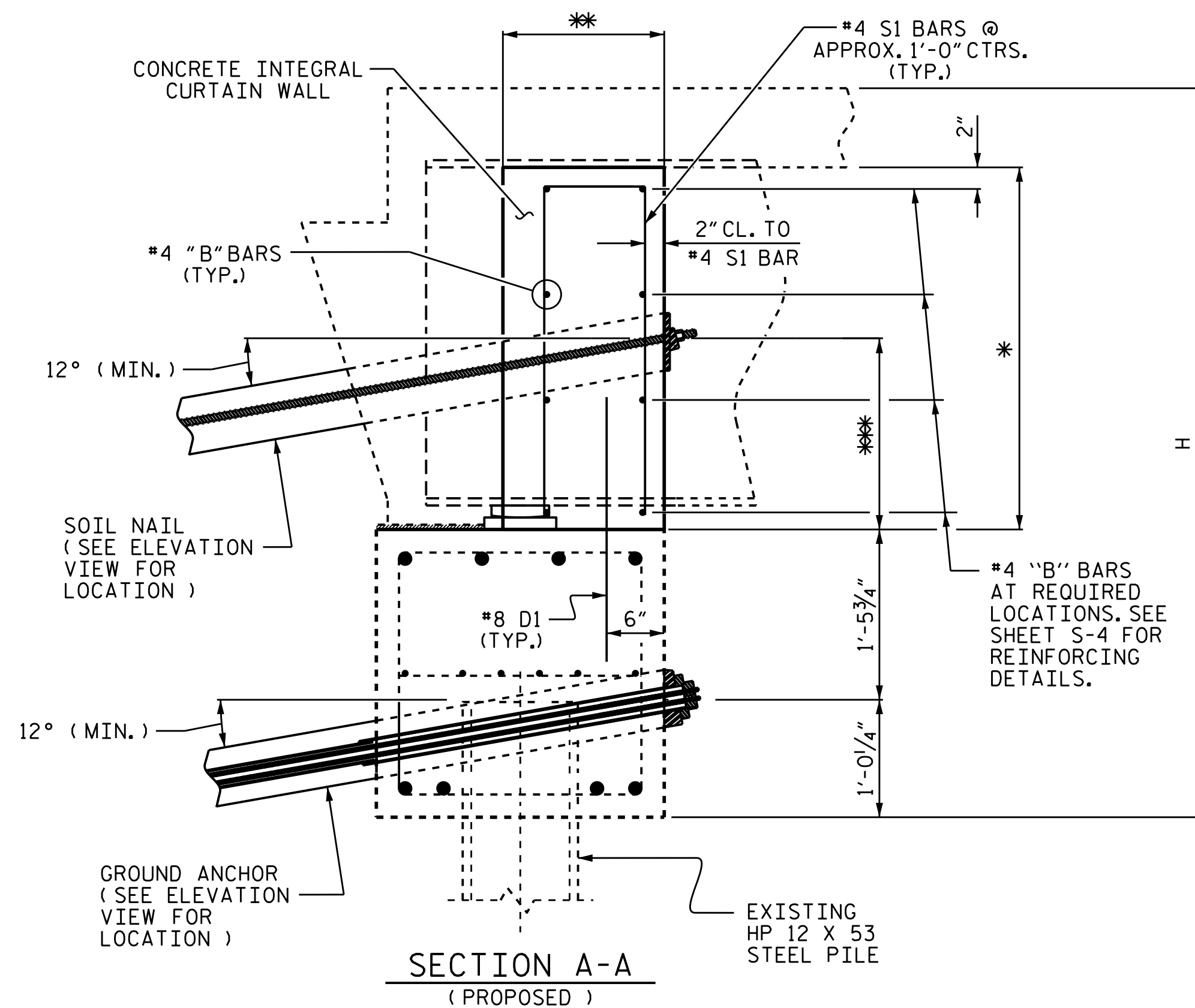

* DISTANCE BETWEEN TOP OF END BENT CAP AND DECK SLAB VARIES DUE TO STEP IN CAP AND SLOPE OF DECK SLAB. THE MINIMUM DIMENSION IS APPROX. 2'-10 1/2" AND THE MAXIMUM DIMENSION IS APPROXIMATELY 3'-4". SEE ELEVATION VIEW.

** DISTANCE BETWEEN FACE OF END BENT CAP AND FACE OF CURTAIN WALL VARIES. THE MINIMUM DIMENSION IS APPROXIMATELY 1'-2 1/2" AND THE MAXIMUM DIMENSION IS APPROXIMATELY 1'-4 3/4".

*** 1'-9" FOR SOIL NAILS IN BAYS 1 AND 3 AND 1'-2 1/2" FOR SOIL NAILS IN BAY 2

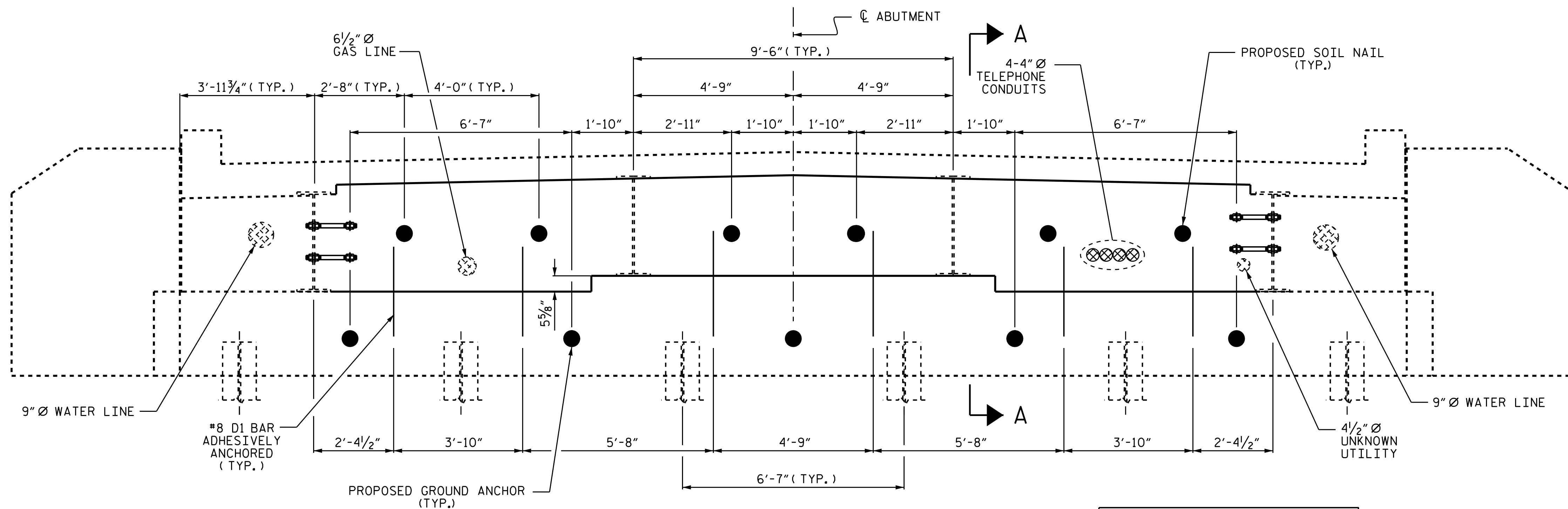

ELEVATION
SEE SHEET 2 FOR REINFORCEMENT LOCATIONS

END BENT 1 INDICATED,
END BENT 2 SIMILAR

NOTES:

EXISTING DIMENSIONS AND BRIDGE CONDITION ARE FROM BEST INFORMATION AVAILABLE. THE CONTRACTOR SHALL FIELD VERIFY THE INFORMATION SHOWN ON THE PLANS AND NOTIFY THE ENGINEER IF ACTUAL DIMENSIONS AND CONDITIONS DIFFER.

HOLES THROUGH THE CURTAIN WALL AND BENT CAP SHALL BE CORED, PRIOR TO INSTALLATION OF SOIL NAILS OR GROUND ANCHORS. PRIOR TO ANY CORING, USING A PACHOMETER, CHECK THE CAP AND CURTAIN WALL FOR MAIN REINFORCING STEEL INTERFERENCE WITH SOIL NAIL AND GROUND ANCHOR LOCATIONS. IF NECESSARY, ADJUST SOIL NAIL AND GROUND ANCHOR LOCATIONS SLIGHTLY TO AVOID REINFORCING STEEL.

FOR "SOIL NAILS", SEE SPECIAL PROVISIONS.

FOR "GROUND ANCHORS", SEE SPECIAL PROVISIONS.

BEFORE BEGINNING SOIL NAIL OR ANCHOR LOCATIONS, DESIGN, SURVEY, AND SUBMIT DESIGN AND CALCULATIONS FOR REVIEW. DO NOT START CONSTRUCTION UNTIL THE SUBMITTED SOIL NAIL AND ANCHOR DESIGN IS ACCEPTED.

DESIGN SOIL NAILS FOR THE FOLLOWING:

1. FACTORED TENSILE LOAD = 30,000 LBS.
2. DESIGN LIFE = 75 YEARS
3. IN-SITU ASSUMED MATERIAL PARAMETERS
UNIT WEIGHT, $\gamma = 120$ LB/CF
FRICTION ANGLE, $\phi = 30^\circ$

DESIGN GROUND ANCHORS FOR THE FOLLOWING:

1. FACTORED TENSILE LOAD = 40,000 LBS.
2. DESIGN LIFE = 75 YEARS
3. IN-SITU ASSUMED MATERIAL PARAMETERS
UNIT WEIGHT, $\gamma = 120$ LB/CF
FRICTION ANGLE, $\phi = 30^\circ$
LOCK-OFF LOAD = 30,000 LBS.

EXISTING OR FUTURE OBSTRUCTIONS SUCH AS FOUNDATIONS, GUARDRAIL, FENCE OR HANDRAIL POSTS, PAVEMENTS, PIPES, INLETS, OR UTILITIES MAY INTERFERE WITH SOIL NAILS. CONTRACTOR SHALL VERIFY IF OBSTRUCTIONS TO THE INSTALLATION OF THE SOIL NAILS OR GROUND ANCHORS EXIST. PRIOR TO INSTALLATION. IF OBSTRUCTIONS EXIST, THE CONTRACTOR SHALL NOT PROCEED WITH INSTALLATION UNTIL A RESOLUTION TO THE OBSTRUCTION IS AGREED TO BY THE ENGINEER.

ALL NAIL AND ANCHOR PLATES, NUTS, WASHERS, AND EXPOSED STEEL SHALL BE GALVANIZED IN ACCORDANCE WITH THE STANDARD SPECIFICATIONS.

PROJECT NO. 12B.101811
CATAWBA COUNTY
BRIDGE NO. 91

SHEET 1 OF 2

STATE OF NORTH CAROLINA
DEPARTMENT OF TRANSPORTATION
RALEIGH

END BENT
PROPOSED REPAIRS

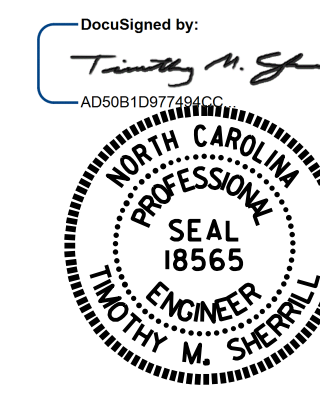

4/19/2017

DRAWN BY : R. WEISZ DATE : 1/13
CHECKED BY : T. SHERRILL DATE : 3/13

REVISIONS						SHEET NO.
NO.	BY:	DATE:	NO.	BY:	DATE:	S-3
1			3			TOTAL SHEETS
2			4			4

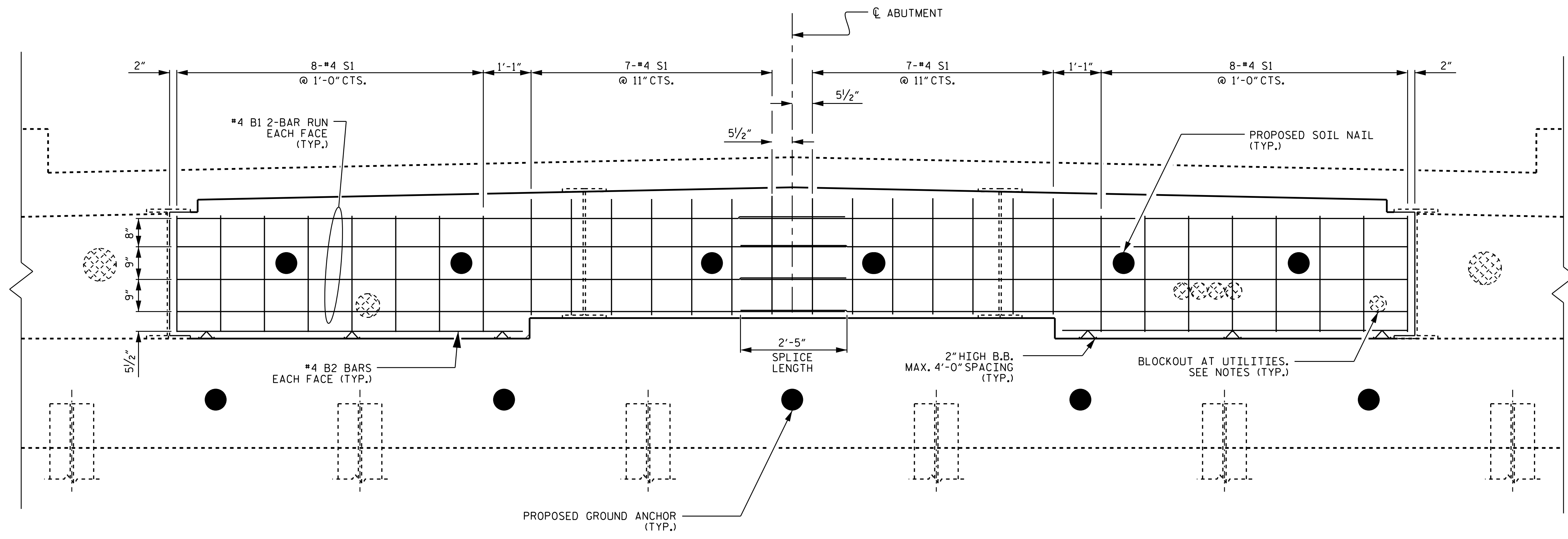

ELEVATION

REINFORCEMENT SHOWN, DOWEL BARS AND ANCHOR BOLTS NOT SHOWN FOR CLARITY
 UTILITY LOCATIONS ARE APPROXIMATE. SOIL NAILS AND GROUND ANCHORS MAY BE SHIFTED SLIGHTLY TO AVOID CONFLICTS.

END BENT 1 INDICATED,
 END BENT 2 SIMILAR

PROJECT NO. 12B.101811
 CATAWBA COUNTY
 BRIDGE NO. 91

SHEET 2 OF 2

STATE OF NORTH CAROLINA
 DEPARTMENT OF TRANSPORTATION
 RALEIGH

REINFORCEMENT IN
 INTEGRAL
 CURTAIN WALL

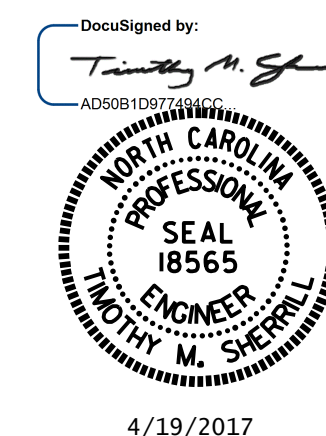

4/19/2017

DRAWN BY : R. WEISZ DATE : 1/13
 CHECKED BY : T. SHERRILL DATE : 3/13

06-APR-2017 12:54
 S:\DPC3\Wael\Tracy\Catawba 91.EB.PCB.dgn
 taverette

REVISIONS						SHEET NO.
NO.	BY:	DATE:	NO.	BY:	DATE:	S-4
1			3			TOTAL SHEETS
2			4			4

STANDARD NOTES

DESIGN DATA:

SPECIFICATIONS	- - - - -	A.A.S.H.T.O. (CURRENT)
LIVE LOAD	- - - - -	SEE PLANS
IMPACT ALLOWANCE	- - - - -	SEE A.A.S.H.T.O.
STRESS IN EXTREME FIBER OF		
STRUCTURAL STEEL - AASHTO M270 GRADE 36	-	20,000 LBS. PER SQ. IN.
- AASHTO M270 GRADE 50W	-	27,000 LBS. PER SQ. IN.
- AASHTO M270 GRADE 50	-	27,000 LBS. PER SQ. IN.
REINFORCING STEEL IN TENSION		
GRADE 60	- -	24,000 LBS. PER SQ. IN.
CONCRETE IN COMPRESSION	- - - - -	1,200 LBS. PER SQ. IN.
CONCRETE IN SHEAR	- - - - -	SEE A.A.S.H.T.O.
STRUCTURAL TIMBER - TREATED OR		
UNTREATED - EXTREME FIBER STRESS	- - - - -	1,800 LBS. PER SQ. IN.
COMPRESSION PERPENDICULAR TO GRAIN OF TIMBER	- - - - -	375 LBS. PER SQ. IN.
EQUIVALENT FLUID PRESSURE OF EARTH	- - - - -	30 LBS. PER CU. FT. (MINIMUM)

MATERIAL AND WORKMANSHIP:

EXCEPT AS MAY OTHERWISE BE SPECIFIED ON PLANS OR IN THE SPECIAL PROVISIONS, ALL MATERIAL AND WORKMANSHIP SHALL BE IN ACCORDANCE WITH THE 2012 "STANDARD SPECIFICATIONS FOR ROADS AND STRUCTURES" OF THE N. C. DEPARTMENT OF TRANSPORTATION.

STEEL SHEET PILING FOR PERMANENT OR TEMPORARY APPLICATIONS SHALL BE HOT ROLLED.

CONCRETE:

UNLESS OTHERWISE REQUIRED ON PLANS, CLASS A CONCRETE SHALL BE USED FOR ALL PORTIONS OF ALL STRUCTURES WITH THE EXCEPTION THAT; CLASS AA CONCRETE SHALL BE USED IN BRIDGE SUPERSTRUCTURES, ABUTMENT BACKWALLS, AND APPROACH SLABS; AND CLASS B CONCRETE SHALL BE USED FOR SLOPE PROTECTION AND RIP RAP.

CONCRETE CHAMFERS:

UNLESS OTHERWISE NOTED ON THE PLANS, ALL EXPOSED CORNERS ON STRUCTURES SHALL BE CHAMFERED 3/4" WITH THE FOLLOWING EXCEPTIONS: TOP CORNERS OF CURBS MAY BE ROUNDED TO 1-1/2" RADIUS WHICH IS BUILT INTO CURB FORMS; CORNERS OF TRANSVERSE FLOOR EXPANSION JOINTS SHALL BE ROUNDED WITH A 1/4" FINISHING TOOL UNLESS OTHERWISE REQUIRED ON PLANS; AND CORNERS OF EXPANSION JOINTS IN THE ROADWAY FACES AND TOPS OF CURBS AND SIDEWALKS SHALL BE ROUNDED TO A 1/4" RADIUS WITH A FINISHING STONE OR TOOL UNLESS OTHERWISE REQUIRED ON PLANS.

DOWELS:

DOWELS WHEN INDICATED ON PLANS AS FOR CULVERT EXTENSIONS, SHALL BE EMBEDDED AT LEAST 12" INTO THE OLD CONCRETE AND GROUTED INTO PLACE WITH 1:2 CEMENT MORTAR.

ALLOWANCE FOR DEAD LOAD DEFLECTION, SETTLEMENT, ETC. IN CASTING SUPERSTRUCTURES:

BRIDGES SHALL BE BUILT ON THE GRADE OR VERTICAL CURVE SHOWN ON PLANS. SLABS, CURBS AND PARAPETS SHALL CONFORM TO THE GRADE OR CURVE.

ALL DIMENSIONS WHICH ARE GIVEN IN SECTION AND ARE AFFECTED BY DEAD LOAD DEFLECTIONS ARE DIMENSIONS AT CENTER LINE OF BEARING UNLESS OTHERWISE NOTED ON PLANS. IN SETTING FORMS FOR STEEL BEAM BRIDGES AND PRESTRESSED CONCRETE GIRDER BRIDGES, ADJUSTMENTS SHALL BE MADE DUE TO THE DEAD LOAD DEFLECTIONS FOR THE ELEVATIONS SHOWN. WHERE BLOCKS ARE SHOWN OVER BEAMS FOR BUILDING UP TO THE SLAB, THE VERTICAL DIMENSIONS OF THE BLOCKS SHALL BE ADJUSTED BETWEEN BEARINGS TO COMPENSATE FOR DEAD LOAD DEFLECTIONS, VERTICAL CURVE ORDINATE, AND ACTUAL BEAM CAMBER. WHERE BOTTOM OF SLAB IS IN LINE WITH BOTTOM OF TOP FLANGES, DEPTH OF SLAB BETWEEN BEARINGS SHALL BE ADJUSTED TO COMPENSATE FOR DEAD LOAD DEFLECTION, VERTICAL CURVE ORDINATE, AND ACTUAL BEAM CAMBER.

IN SETTING FALSEWORK AND FORMS FOR REINFORCED CONCRETE SPANS, AN ALLOWANCE SHALL BE MADE FOR DEAD LOAD DEFLECTIONS, SETTLEMENT OF FALSEWORK, AND PERMANENT CAMBER WHICH SHALL BE PROVIDED FOR IN ADDITION TO THE ELEVATIONS SHOWN. AFTER REMOVAL OF THE FALSEWORK, THE FINISHED STRUCTURES SHALL CONFORM TO THE PROFILE AND ELEVATIONS SHOWN ON THE PLANS AND CONSTRUCTION ELEVATIONS FURNISHED BY THE ENGINEER.

DETAILED DRAWINGS FOR FALSEWORK OR FORMS FOR BRIDGE SUPERSTRUCTURE AND ANY STRUCTURE OR PARTS OF A STRUCTURE AS NOTED ON THE PLANS SHALL BE SUBMITTED TO THE ENGINEER FOR APPROVAL BEFORE CONSTRUCTION OF THE FALSEWORK OR FORMS IS STARTED.

REINFORCING STEEL:

ALL REINFORCING STEEL SHALL BE DEFORMED. DIMENSIONS RELATIVE TO PLACEMENT OF REINFORCING ARE TO CENTERS OF BARS UNLESS OTHERWISE INDICATED IN THE PLANS. DIMENSIONS ON BAR DETAILS ARE TO CENTERS OF BARS OR ARE OUT TO OUT AS INDICATED ON PLANS.

WIRE BAR SUPPORTS SHALL BE PROVIDED FOR REINFORCING STEEL WHERE INDICATED ON THE PLANS. WHEN BAR SUPPORT PIECES ARE PLACED IN CONTINUOUS LINES, THEY SHALL BE SO PLACED THAT THE ENDS OF THE SUPPORTING WIRES SHALL BE LAPPED TO LOCK LEGS ON ADJOINING PIECES.

STRUCTURAL STEEL:

AT THE CONTRACTOR'S OPTION, HE MAY SUBSTITUTE 7/8" Ø SHEAR STUDS FOR THE 3/4" Ø STUDS SPECIFIED ON THE PLANS. THIS SUBSTITUTION SHALL BE MADE AT THE RATE OF 3 - 7/8" Ø STUDS FOR 4 - 3/4" Ø STUDS, AND STUD SPACING CHANGES SHALL BE MADE AS NECESSARY TO PROVIDE THE SAME EQUIVALENT NUMBER OF 7/8" Ø STUDS ALONG THE BEAM AS SHOWN FOR 3/4" Ø STUDS BASED ON THE RATIO OF 3 - 7/8" Ø STUDS FOR 4 - 3/4" Ø STUDS. STUDS OF THE LENGTH SPECIFIED ON THE PLANS MUST BE PROVIDED. THE MAXIMUM SPACING SHALL BE 2'-0".

EXCEPT AT THE INTERIOR SUPPORTS OF CONTINUOUS BEAMS WHERE THE COVER PLATE IS IN CONTACT WITH BEARING PLATE, THE CONTRACTOR MAY, AT HIS OPTION, SUBSTITUTE FOR THE COVER PLATES DESIGNATED ON THE PLANS COVER PLATES OF THE EQUIVALENT AREA PROVIDED THESE PLATES ARE AT LEAST 5/16" IN THICKNESS AND DO NOT EXCEED A WIDTH EQUAL TO THE FLANGE WIDTH LESS 2" OR A THICKNESS EQUAL TO 2 TIMES THE FLANGE THICKNESS. THE SIZE OF FILLET WELDS SHALL CONFORM TO THE REQUIREMENTS OF THE CURRENT ANSI/AASHTO/AWS "BRIDGE WELDING CODE". ELECTROSLAG WELDING WILL NOT BE PERMITTED.

WITH THE SOLE EXCEPTION OF EDGES AT SURFACES WHICH BEAR ON OTHER SURFACES, ALL SHARP EDGES AND ENDS OF SHAPES AND PLATES SHALL BE SLIGHTLY ROUNDED BY SUITABLE MEANS TO A RADIUS OF APPROXIMATELY 1/16 INCH OR EQUIVALENT FLAT SURFACE AT A SUITABLE ANGLE PRIOR TO PAINTING, GALVANIZING, OR METALLIZING.

HANDRAILS AND POSTS:

METAL STANDARDS AND FACES OF THE CONCRETE END POSTS FOR THE METAL RAIL SHALL BE SET NORMAL TO THE GRADE OF THE CURB, UNLESS OTHERWISE SHOWN ON PLANS. THE METAL RAIL AND TOPS OF CONCRETE POSTS USED WITH THE ALUMINUM RAIL SHALL BE BUILT PARALLEL TO THE GRADE OF THE CURB.

METAL HANDRAILS SHALL BE IN ACCORDANCE WITH THE PLANS. RAILS SHALL BE AS MANUFACTURED FOR BRIDGE RAILING. CASTINGS SHALL BE OF A UNIFORM APPEARANCE. FINIS AND OTHER DEFORMATIONS RESULTING FROM CASTING OR OTHERWISE SHALL BE REMOVED IN A MANNER SO THAT A UNIFORM COLORING OF THE COMPLETED CASTING SHALL BE OBTAINED. CASTINGS WITH DISCOLORATIONS OR OF NON-UNIFORM COLORING WILL NOT BE ACCEPTED. CERTIFIED MILL REPORTS ARE REQUIRED FOR METAL RAILS AND POSTS.

SPECIAL NOTES:

GENERALLY, IN CASE OF DISCREPANCY, THIS STANDARD SHEET OF NOTES SHALL GOVERN OVER THE SPECIFICATIONS, BUT THE REMAINDER OF THE PLANS SHALL GOVERN OVER NOTES HEREON, AND SPECIAL PROVISIONS SHALL GOVERN OVER ALL. SEE SPECIFICATIONS ARTICLE 105-4.

ENGLISH

JANUARY, 1990